

# KBL121200 12V 120Ah



The KAISE LONG LIFE Series 10 years has been designed for different applications, such as UPS, electric and telecommunications applications that require a long useful life.

## Performance Characteristics

Nominal Voltage	12V	
Dimensions	Length (mm / inch)	410 / 16.14
	Width (mm / inch)	176 / 6.93
	Height (mm / inch)	224 / 8.82
	Total Height (mm / inch)	224 / 8.82
Approx. Weight (Kg / lbs)	38 / 83.8	
Design Life	10 years	
Terminal	M8	
Container Material	ABS	
Rated Capacity	124Ah / 12.4A	(10hr, 1.70V / cell, 25°C / 77°F)
	105.5Ah / 21.1A	(5hr, 1.70V / cell, 25°C / 77°F)
	77.4Ah / 7.74A	(1hr, 1.70V / cell, 25°C / 77°F)
Max. Discharge Current	900A (5s)	
Internal Resistance	Approx 5.2 mΩ	
Operating Temp. Range	Discharge : -20 ~ 60°C (-4 ~ 140°F)	
	Charge : -10 ~ 60°C (14 ~ 140°F)	
	Storage : -20 ~ 60°C (-4 ~ 140°F)	
Nominal Operating Temp. Range	25 ± 3°C (77 ± 5°F)	
Cycle Use	Initial Charging Current less than 20A.	
	Voltage: 2.30VPC ~ 2.35VPC at 25°C (77°F)	
	Temp. Coefficient: -30mV/°C	
Standby Use	Initial Charging Current less than 20A.	
	2.25VPC~2.30VPC at 25° C (77°F)	
	Temp. Coefficient: -20mV/°C	
Capacity affected by	40°C (104°F)	103%
	25°C (77°F)	100%
	0°C (32°F)	86%
Self Discharge	Fully charged Kaise Long Life Series batteries may be stored for up to 6 months at 25°C (77°F) and then a freshening charge is required. For higher temperatures the time interval will be shorter.	

## ConstDescarga a Corriente Constante (Amperes) a 77°F (25°C)

Volts/cell	10min	15min	30min	1h	3h	5h	10h	20h
1.80V	221	192	114	72.7	29.3	20.3	12.0	6.36
1.75V	236	201	116	75.1	30.1	20.7	12.2	6.44
1.70V	251	210	121	77.4	30.8	21.1	12.4	6.50
1.65V	266	219	125	79.0	31.4	21.5	12.5	6.54
1.60V	281	228	129	79.6	32.1	21.8	12.6	6.58

## Dimensions and Terminal (Unit: mm (inches))

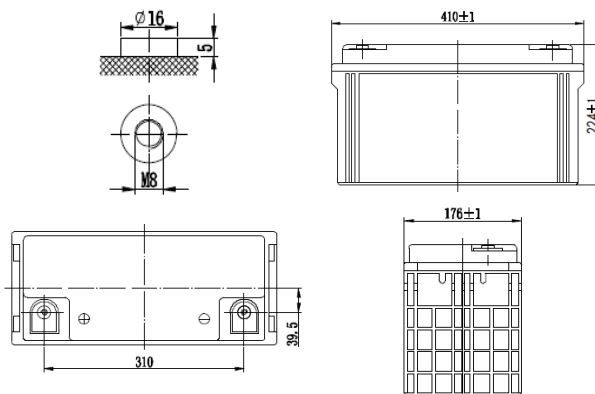

## Applications

- UPS
- Telecommunications equipment
- Solar energy systems
- Cable TV
- Power station
- Marine equipment
- Military equipment
- Emergency power systems
- Railway systems

## Certifications

ISO 9001:2008 ISO 14001:2008



## Discharge Current vs. Discharge Voltage

Final discharge voltage V/CELL	1.8	1.75	1.7	1.6
Discharge current (A)	$I \leq 0.1CA$	$0.25CA \geq I > 0.1CA$	$0.55CA \geq I > 0.25CA$	$I > 0.55CA$

## Constant Power Discharge (Watts per cell) at 77°F (25°C)

Volts/cell	10min	15min	30min	45min	1h	2h	3h	5h
1.80V	402	350	215	158	145	81.9	58.5	41.6
1.75V	430	363	222	161	150	82.7	59.5	42.0
1.70V	454	376	230	165	154	84.2	60.2	42.2
1.65V	479	389	236	168	156	85.8	60.9	42.6
1.60V	504	402	244	172	159	87.4	61.6	42.8

(Note) The above characteristics data are average values obtained within three charge/discharge cycles not the minimum values.

## Charging Characteristics (float use)

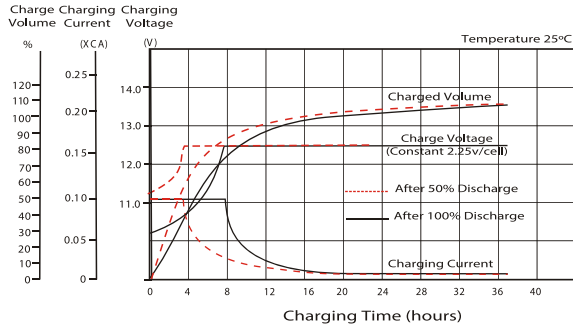

## Cycle Life in Relation to Depth of Discharge

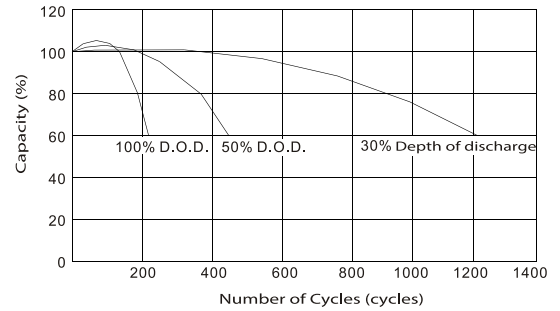

## Temperature Effects in Relation to Battery Capacity

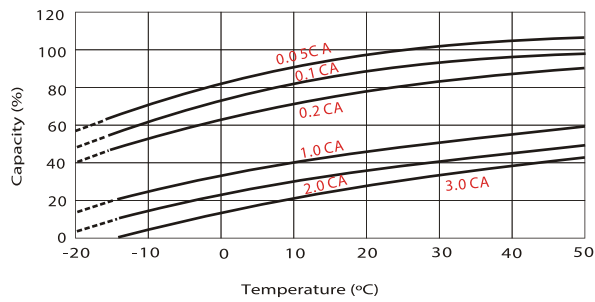

## Effect of Temperature on Long Term Float Life

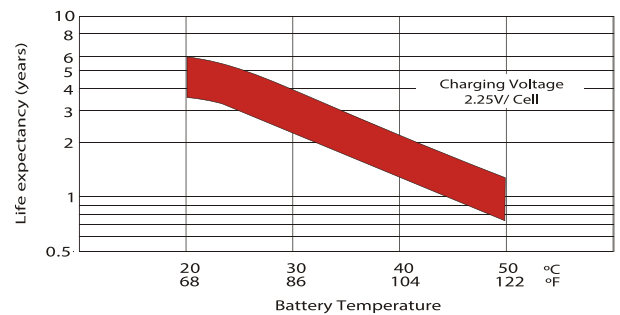

## Self Discharge Characteristics

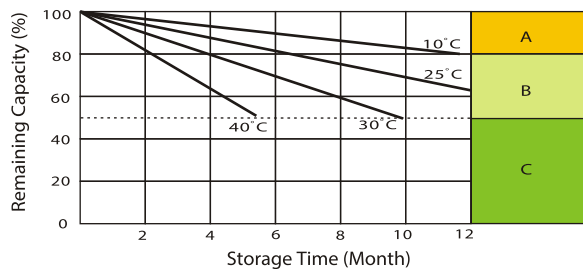

- A** No supplementary charge required (carry out supplementary charge before use if 100% capacity is required)
- B** Supplementary charge required before use. Optional charging way a below:
  1. Charged for above 3 days at limited current 0.25 CA and constant voltage 2.25V / cell.
  2. Charged for above 20 hours limited current 0.25CA and constant voltage 2.45V / cell.
  3. Charged for 8-10 hours at limited current 0.05 CA.
- C** Supplementary charge often fail to recover the capacity. The battery should never be left standing till this is reached.

NOTA IMPORTANTE: Las especificaciones presentadas en este documento están sujetos a revisión sin previo aviso.

