

# KBASL122500 12V 250Ah



The Kaise Solar range is mainly used in the renewable energies industry, given their optimal performance in cyclic use. With lower acid density, excess of electrolyte and larger distance between plates the batteries maintain a low temperature and also slows down the plate grid corrosion speed. These batteries have a unique plate grid configuration which, alongside the high quality AGM separator and the battery management system, ensures the batteries have a longer service life. The valves were specially designed to control water loss and prevent air and other elements from getting in.



## Performance Characteristics

Nominal Voltage	12V	
Dimensions	Length (mm / inch)	522±2 / 20.6
	Width (mm / inch)	240±2 / 9.45
	Height (mm / inch)	218±2 / 8.58
	Total Height (mm / inch)	224±2 / 8.82
Approx. Weight	(Kg / lbs) 58 / 127.9	
Design Life	8 - 12 years	
Terminal	M8	
Container Material	ABS	
Rated Capacity	250.0Ah / 2.50 A	(100hr, 1.80V/cell, 25°C / 77°F)
	210.0Ah / 10.5 A	(20hr, 1.80V/cell, 25°C / 77°F)
	172.0 Ah / 34.4A	(5hr, 1.80V/cell, 25°C / 77°F)
	129.3 Ah / 129.3 A	(1hr, 1.60V/cell, 25°C / 77°F)
Max. Discharge Current	2000A (5s)	
Internal Resistance	Approx 3.2mΩ	
Operating Temp. Range	Discharge : -20 ~ 55°C (-4 ~ 131°F)	
	Charge : 0 ~ 40°C (32 ~ 104°F)	
	Storage : -15 ~ 50°C (5 ~ 122°F)	
Nominal Operating Temp. Range	25 ± 3°C (77 ± 5°F)	
Cycle Use	Initial Charging Current less than 50.0A	
	Voltage: 14.1V ~ 14.4V at 25°C (77°F)	
	Temp. Coefficient: -30mV/°C	
Standby Use	Initial Charging Current less than 50.0A	
	Voltage: 13.5V ~ 13.8V at 25°C (77°F)	
	Temp. Coefficient: -20mV/°C	
Capacity affected by Temperature	40°C (104°F)	103%
	25°C (77°F)	100%
	0°C (32°F)	86%
Self Discharge	Fully charged Kaise Solar Series batteries may be stored for up to 6 months at 25°C (77°F) and then a freshening charge is required. For higher temperatures the time interval will be shorter.	

## Constant Current Discharge (Amperes) at 77°F (25°C)

Volts/cell	1h	2h	5h	8h	10h	20h	100h
1.80V	111.3	63.1	34.4	24.0	20.0	10.5	2.50
1.75V	118.0	65.9	35.6	24.4	20.4	10.7	2.52
1.70V	123.4	68.4	36.2	24.8	20.6	10.8	2.55
1.67V	127.8	70.5	36.8	25.2	20.8	10.9	2.59
1.60V	129.3	71.6	37.4	25.4	21.0	11.0	2.61

## Dimensions and Terminal (Unit: mm (inches))

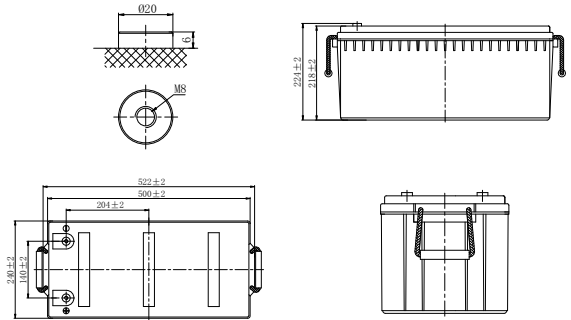

## Applications

- Renewable Energy
- Alarm systems
- Electric Test Equipment
- Emergency lighting systems
- Marine equipment
- Telecommunications systems

## Certifications

ISO 9001:2008 ISO 14001:2008



## Discharge Current vs. Discharge Voltage

Final discharge voltage V/CELL	1.8	1.75	1.7	1.6
Discharge current (A)	$I \leq 0.1CA$	$0.25CA \geq I > 0.1CA$	$0.55CA \geq I > 0.25CA$	$I > 0.55CA$

## Constant Power Discharge (Watts per cell) at 77°F (25°C)

Volts/cell	1h	2h	5h	8h	10h	20h
1.80V	214.8	122.7	67.5	47.3	39.5	20.9
1.75V	226.3	127.5	69.7	48.0	40.2	21.3
1.70V	234.9	131.6	70.6	48.7	40.6	21.5
1.67V	242.1	135.1	71.6	49.4	40.9	21.6
1.60V	242.6	136.3	72.5	49.7	41.2	21.8

(Note) The above characteristics data are average values obtained within three charge/discharge cycles not the minimum values.

## Charging Characteristic

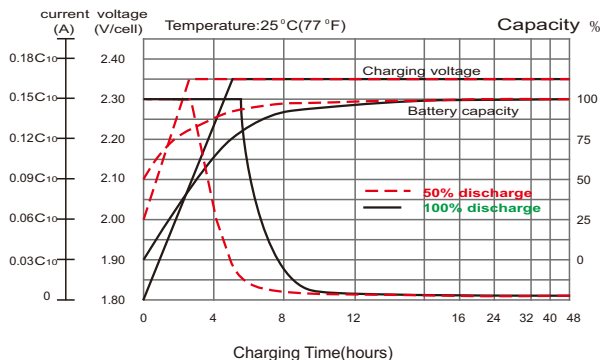

## Self Discharge Characteristics

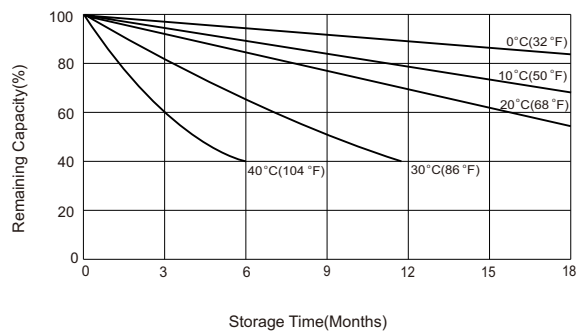

## Cycle Life in Relation to Depth of Discharge

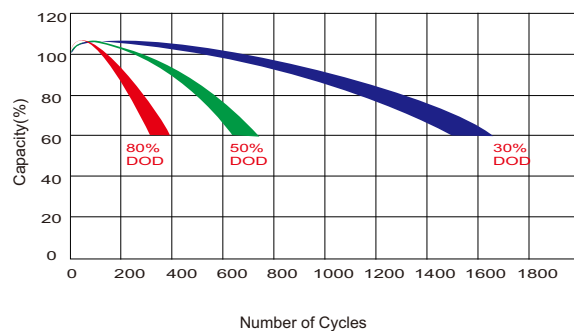

## Temperature Effects in Relation to Battery Capacity

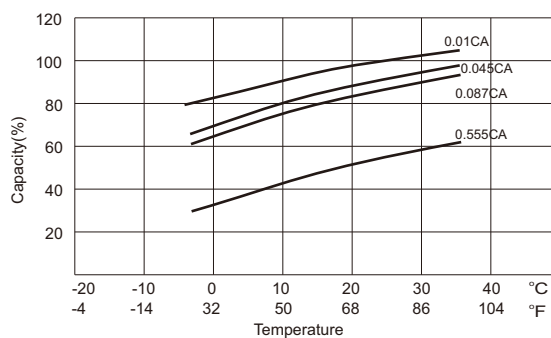

IMPORTANT NOTE: The specifications presented herein are subject to revision without notice.

2021/VI

