

KBHR121000 12V 100Ah



The Kaise HR batteries were specially designed for applications that demand a very high energy output. With an optimized design of the grids and an excellent formula for pasting the plates, the HR series can deliver up to 40% more than the standard series.



Performance Characteristics

Nominal Voltage	12V	
Dimensions	Length (mm / inch)	325.5 / 12.81
	Width (mm / inch)	170 / 6.69
	Height (mm / inch)	213 / 8.39
	Total Height (mm / inch)	216 / 8.50
Approx Weight	(Kg / lbs) 31.6 / 69.7	
Design Life	12 years	
Terminal	M6	
Container Material	ABS	
Rated Capacity	67.8Ah / 67.8A	(1hr, 1.70V / cell, 25°C / 77°F)
	63.35Ah / 126.7A	(30min, 1.70V / cell, 25°C / 77°F)
	52.95Ah / 211.8A	(15min, 1.70V / cell, 25°C / 77°F)
Max. Discharge Current	1655A (5s)	
Internal Resistance	Approx 3.6mΩ	
Operating Temp. Range	Discharge : -15 ~ 50°C (5 ~ 122°F)	
	Charge : 0 ~ 40°C (32 ~ 104°F)	
	Storage : -15 ~ 40°C (5 ~ 104°F)	
Nominal Operating Temp. Range	25 ± 3°C (77 ± 5°F)	
Max. Charging Current (25°C)	30.0A	
Capacity affected by Temperature	40°C (104°F)	103%
	25°C (77°F)	100%
	0°C (32°F)	86%
Self Discharge	Fully charged Kaise High Rate Series batteries may be stored for up to 6 months at 25°C (77°F) and then a freshening charge is required. For higher temperatures the time interval will be shorter.	

Dimensions and Terminal (Unit: mm (inches))

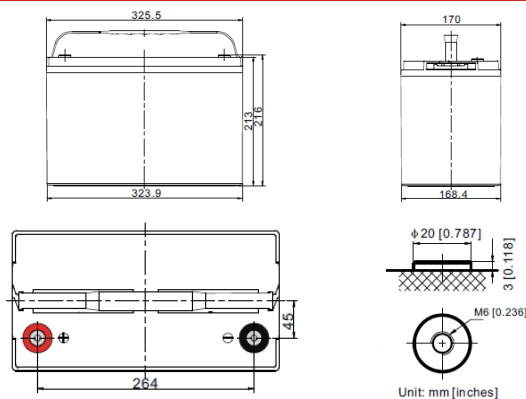

Applications

UPS
High power backup supply
Electric facilities
Power tools

Certifications

ISO 9001:2008 ISO 14001:2008



Discharge Current vs. Discharge Voltage

Final discharge voltage V/CELL	1.8	1.75	1.7	1.6
Discharge current (A)	$I \leq 0.1CA$	$0.25CA \geq I > 0.1CA$	$0.55CA \geq I > 0.25CA$	$I > 0.55CA$

Discharge Constant Current (Amperes) at 77°F (25°C)

Volts/cell	10min	15min	20min	30min	1h	10h
1.80V	220.9	186.4	152.0	114.8	61.5	9.60
1.75V	243.0	200.9	161.7	121.8	65.1	9.81
1.70V	258.7	211.8	169.6	126.7	67.8	10.0
1.60V	285.9	229.4	181.8	133.8	72.4	10.3

Discharge Constant Power (Watts per cell) at 77°F (25°C)

Volts/cell	10min	15min	20min	30min	1h	10h
1.80V	427.7	363.0	297.7	226.2	122.4	19.7
1.75V	466.1	387.8	313.9	237.8	128.6	20.0
1.70V	490.7	404.0	325.8	244.9	133.0	20.2
1.60V	532.5	430.4	343.7	254.8	139.9	20.4

(Note) The above characteristics data are average values obtained within three charge/discharge cycles not the minimum values.

Charging Characteristics (cycle use)

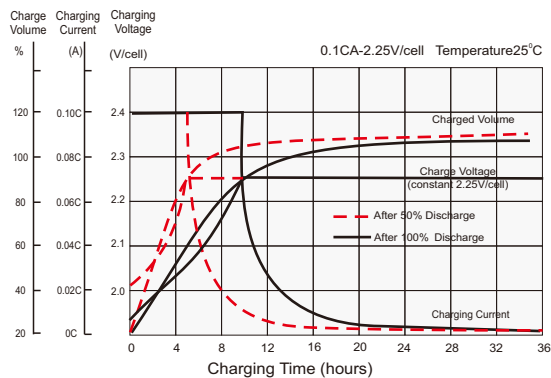

Discharge Characteristics

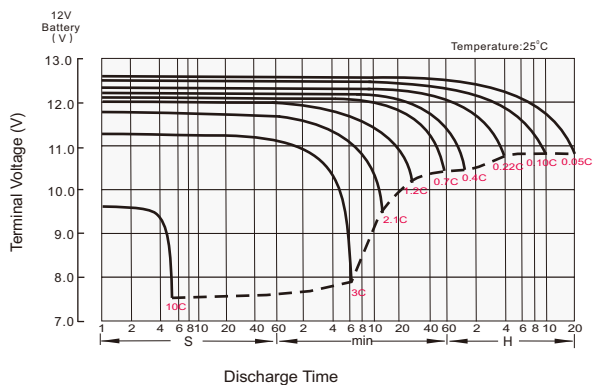

Self Discharge Characteristics

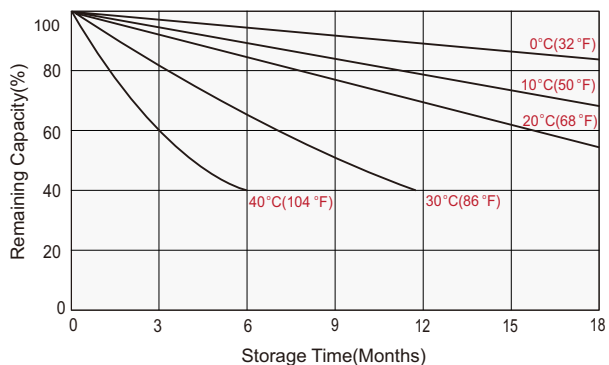

Temperature Effects on Long Term Float Life

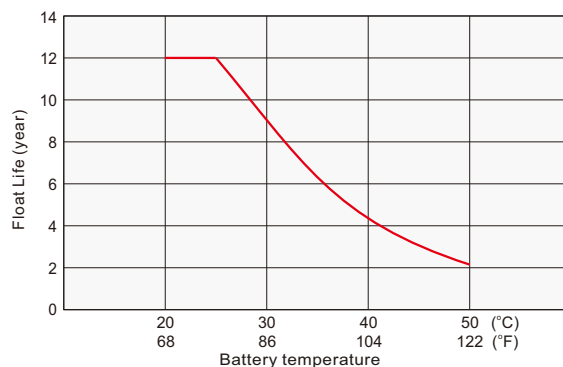

IMPORTANT NOTE: The specifications presented herein are subject to revision without notice.

