

KB670 6V 7.0Ah



The KB Standard series consists in VRLA batteries - AGM technology (Absorbent Glass Mat), with a design life of 3-5 years and it is designed for general applications such as UPS, telecommunications and electrical applications.



Performance Characteristics

Nominal Voltage	6V		
Dimensions	Length (mm / inch)	151 / 5.94	
	Width (mm / inch)	34 / 1.34	
	Height (mm / inch)	94 / 3.70	
	Total Height (mm / inch)	100 / 3.94	
Approx Weight	(Kg / lbs)	1.05 / 2.31	
Design Life	5 years		
Terminal	F1		
Container Material	ABS		
Rated Capacity	7.1Ah / 0.355A	(20hr, 1.80V / cell, 25°C / 77°F)	
	6.69Ah / 0.669A	(10hr, 1.75V / cell, 25°C / 77°F)	
	6.10Ah / 1.22A	(5hr, 1.75V / cell, 25°C / 77°F)	
	4.67Ah / 4.67A	(1hr, 1.60V / cell, 25°C / 77°F)	
Max. Discharge Current	108A (5s)		
Internal Resistance	Approx 13mΩ		
Operating Temp. Range	Discharge : -15 ~ 50°C (5 ~ 122°F)		
	Charge : -20 ~ 40°C (-4 ~ 104°F)		
	Storage : -15 ~ 40°C (5 ~ 104°F)		
Nominal Operating Temp. Range	25 ± 3°C (77 ± 5°F)		
Cycle Use	Initial Charging Current less than 2.16A		
	Voltage: 7.2V ~ 7.5V at 25°C (77°F)		
	Temp. Coefficient: -15mV/°C		
Standby Use	Initial Charging Current less than 2.16A		
	Voltage: 6.75V ~ 6.9V at 25°C (77°F)		
	Temp. Coefficient: -10mV/°C		
Capacity affected by Temperature	40°C (104°F)	103%	
	25°C (77°F)	100%	
	0°C (32°F)	86%	
Self Discharge	Fully charged Kaise Standard Series batteries may be stored for up to 6 months at 25°C (77°F) and then a freshening charge is required. For higher temperatures the time interval will be shorter.		

Discharge Constant Current (Amperes) at 77°F (25°C)

Volts/cell	5min	10min	15min	30min	1h	3h	5h	10h	20h
1.80V	21.8	15.6	12.2	7.21	4.35	1.84	1.21	0.660	0.355
1.75V	23.6	16.2	12.7	7.38	4.43	1.87	1.22	0.669	0.360
1.70V	25.4	17.1	13.1	7.54	4.51	1.89	1.24	0.676	0.362
1.67V	26.4	17.5	13.4	7.65	4.56	1.91	1.25	0.681	0.365
1.60V	28.8	18.6	14.0	7.88	4.67	1.95	1.27	0.692	0.370

Dimensions and Terminal (Unit: mm (inches))

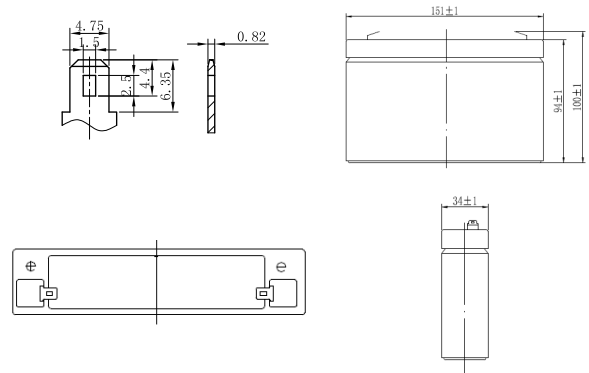

Applications

- Alarm systems
- Cable television
- Communications Equipment
- Control Equipment
- Computers
- Electronic Cash Registers
- Electric Test Equipment
- Emergency lighting systems
- Fire & Security
- Geophysical equipment
- Marine equipment
- Medical equipment
- Micro processor based office machines
- Portable cine & Video lights
- Solar powered systems
- Telecommunications systems
- Television & Video recorders
- Toys
- Uninterruptible power supply systems
- Vending machines

Certifications

ISO 9001:2008 ISO 14001:2008



Discharge Current vs. Discharge Voltage

Final discharge voltage V/CELL	1.8	1.75	1.7	1.6
Discharge current [A]	$I \leq 0.1CA$	$0.25CA \geq I > 0.1CA$	$0.55CA \geq I > 0.25CA$	$I > 0.55CA$

Discharge Constant Power (Watts per cell) at 77°F (25°C)

Volts/cell	5min	10min	15min	30min	45min	1h	2h	3h	5h
1.80V	41.2	29.6	23.3	13.9	10.3	8.44	4.92	3.61	2.38
1.75V	44.2	30.9	24.0	14.1	10.5	8.57	4.98	3.65	2.40
1.70V	47.2	32.1	24.8	14.4	10.6	8.69	5.05	3.70	2.43
1.67V	49.0	32.9	25.2	14.6	10.7	8.76	5.09	3.73	2.45
1.60V	52.9	34.6	26.2	14.9	11.0	8.93	5.17	3.79	2.49

(Note) The above characteristics data are average values obtained within three charge/discharge cycles not the minimum values.

Charging Characteristics (float use)

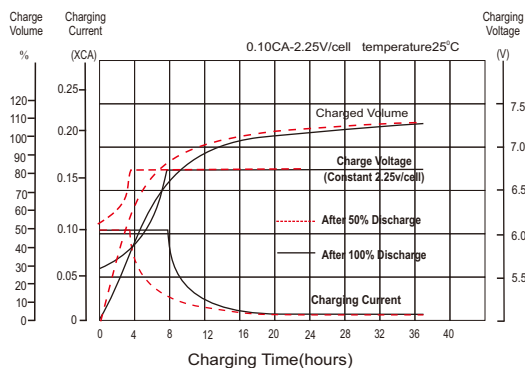

Discharge Characteristics

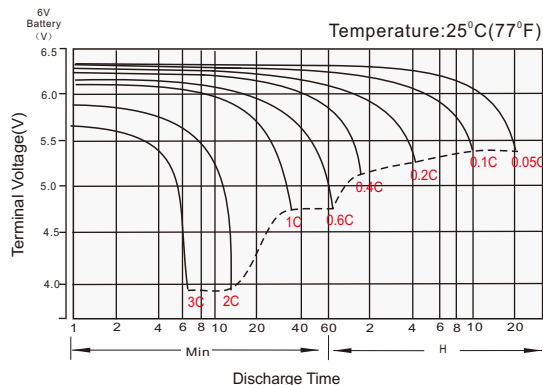

Temperature Effects in Relation to Battery Capacity

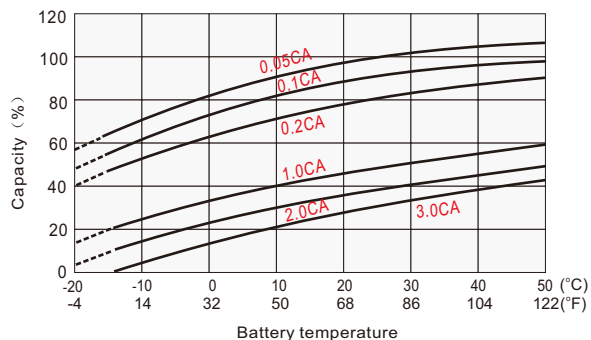

Effect of Temperature on Long Term Float Life

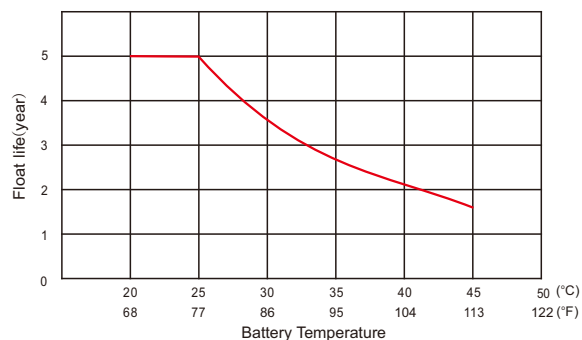

IMPORTANT NOTE: The specifications presented herein are subject to revision without notice.

