

# KBHR690 6V 9Ah



The Kaise HR batteries were specially designed for applications that demand a very high energy output. With an optimized design of the grids and an excellent formula for pasting the plates, the HR series can deliver up to 40% more than the standard series.

## Performance Characteristics

Nominal Voltage	6V	
Capacity	36Wh@15min-rate to 1.67V per cell @25°C	
Dimensions	Length (mm / inch)	151±1.5 / 5.94
	Width (mm / inch)	34±1.5 / 1.34
	Height (mm / inch)	94±1.5 / 3.70
	Total Height (mm / inch)	100±1.5 / 3.94
Approx Weight	(Kg / lbs) 1.35 / 2.98	
Design Life	8 years	
Terminal	F2	
Container Material	A.B.S. UL94-HB, UL94-V0 Optional.	
Rated Capacity	6.105Ah / 6.105A	(1hr, 1.70V / cell, 25°C / 77°F)
	5.40Ah / 10.79A	(30min, 1.70V / cell, 25°C / 77°F)
	4.73Ah / 18.90A	(15min, 1.70V / cell, 25°C / 77°F)
Max. Discharge Current	90A (5s)	
Internal Resistance	Approx. 8mΩ	
Operating Temp. Range	Discharge : -20 ~ 60°C (-4 ~ 140°F)	
	Charge : 0 ~ 50°C (32 ~ 122°F)	
	Storage : -20 ~ 60°C (-4 ~ 140°F)	
Max. Charge Current	2.7A	
Nominal Operating Temp. Range	25 ± 5°C	
Cycle Use	Voltage: 7.3V ~ 7.4V at 25°C (77°F)	
	Temp. Coefficient: -4mV/°C	
Standby Use	Voltage: 6.85V ~ 6.95V at 25°C (77°F)	
	Temp. Coefficient: -3mV/°C	
Capacity affected by Temperature	40°C (104°F)	103%
	25°C (77°F)	100%
	0°C (32°F)	86%
Self Discharge	Fully charged Kaise High Rate Series batteries may be stored for up to 6 months at 25°C (77°F) and then a freshening charge is required. For higher temperatures the time interval will be shorter.	

## Discharge Constant Current (Amperes) at 77°F (25°C)

Volts/cell	10min	15min	20min	30min	1h	1.5h
1.80V	21.95	16.95	13.63	9.889	5.679	4.078
1.75V	23.53	17.85	14.30	10.34	5.900	4.228
1.70V	25.11	18.90	15.06	10.79	6.105	4.360
1.67V	26.05	19.50	15.47	11.06	6.241	4.443
1.60V	28.26	20.85	16.39	11.68	6.548	4.642

## Dimensions and Terminal (Unit: mm (inches))

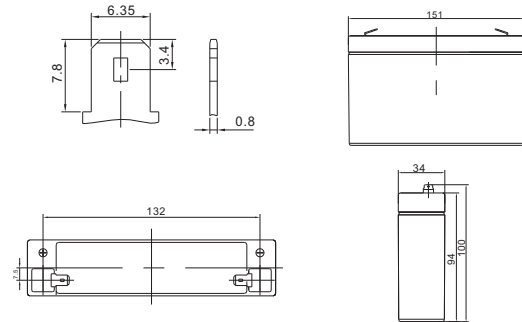

## Applications

UPS  
High power backup supply  
Electric facilities  
Power tools

## Certifications

ISO 9001:2008 ISO 14001:2008



## Discharge Current vs. Discharge Voltage

Final discharge voltage V/CELL	1.8	1.75	1.7	1.6
Discharge current (A)	I ≤ 0.1CA	0.25CA ≥ I > 0.1CA	0.55CA ≥ I > 0.25CA	I > 0.55CA

## Discharge Constant Power (Watts per cell) at 77°F (25°C)

Volts/cell	10min	15min	20min	30min	1h	1.5h
1.80V	41.53	32.10	26.04	19.00	10.98	7.925
1.75V	44.05	33.60	27.11	19.65	11.31	8.140
1.70V	46.42	35.25	28.18	20.29	11.63	8.356
1.67V	47.84	36.00	28.79	20.78	11.82	8.488
1.60V	51.16	38.10	30.17	21.58	12.28	8.787

(Note) The above characteristics data are average values obtained within three charge/discharge cycles not the minimum values.

## Discharge Characteristics Curve

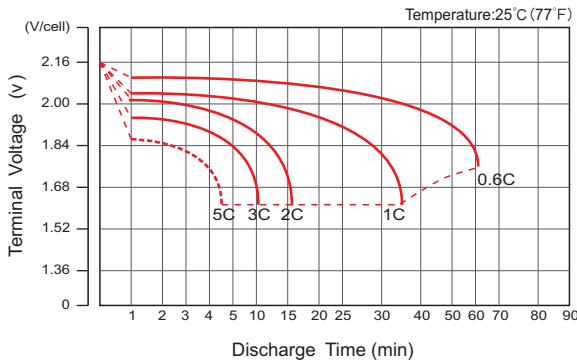

## Charge Characteristic Curve For Standby Use

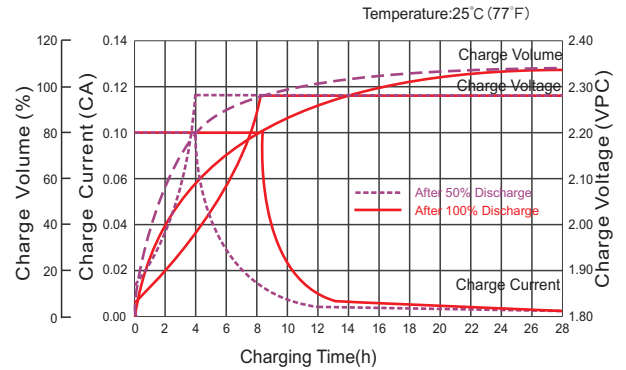

## Storage Characteristics

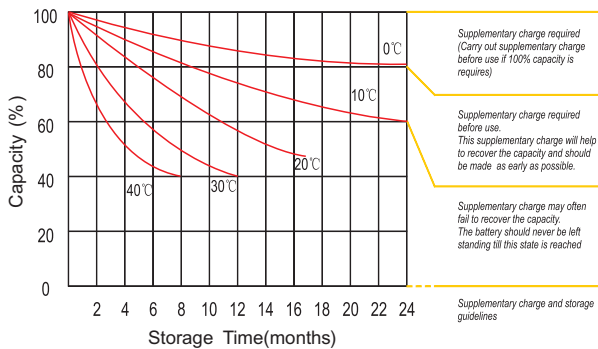

## Relationship Between Charging Voltage And Temperature

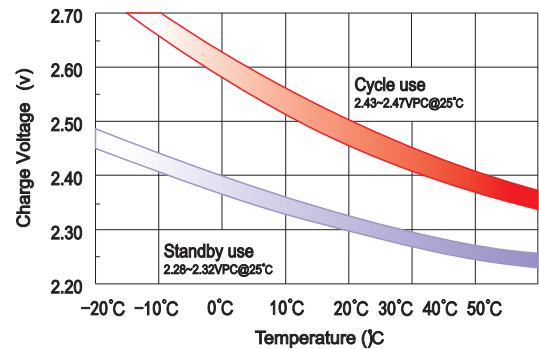

## Temperature Effects On Capacity

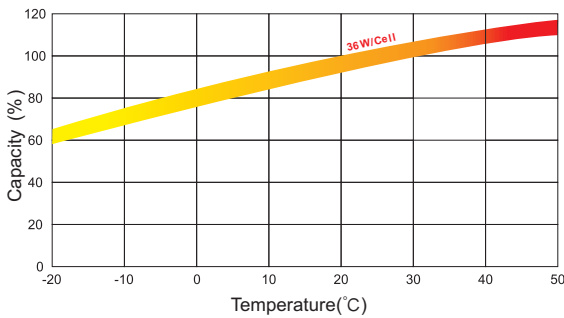

## Relationship of OCV And State of Charge(20°C)

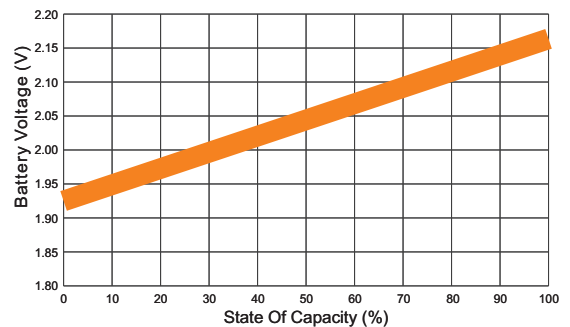

## Effect Of Temperature On Long Term Life

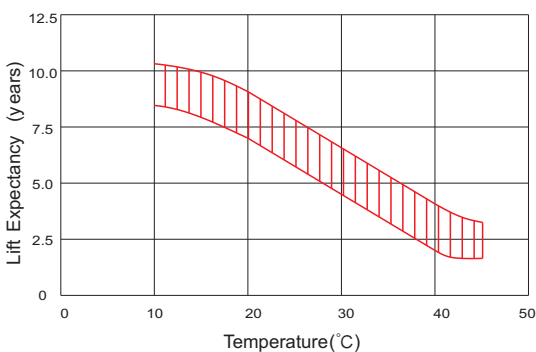

## Life Characteristics Of Standby Use

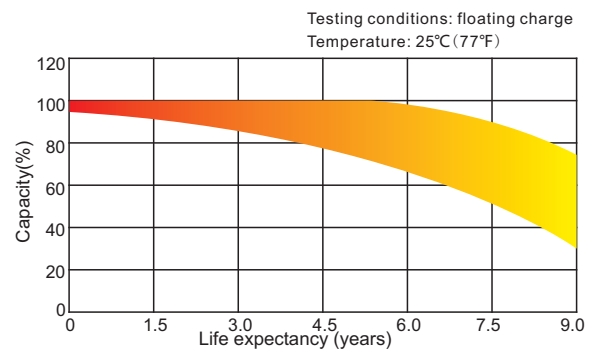

IMPORTANT NOTE: The specifications presented herein are subject to revision without notice.

