

# KB2300 2V 300Ah



The Kaise Ultra Long Life series of VRLA batteries is known for having the most reliable and highest quality of the entire industry. Built with AGM technology, these batteries reach a service life of 20 years.



## Performance Characteristics

Nominal Voltage	2V	
Dimensions	Length (mm / inch)	170 / 6.69
	Width (mm / inch)	150 / 5.91
	Height (mm / inch)	330 / 12.99
	Total Height (mm / inch)	342 / 13.46
Approx. Weight	(Kg / lbs) 16.0 / 35.27	
Design Life	20 years	
Terminal	M8	
Container Material	A.B.S. UL94-HB, UL94-V0 Optional.	
Rated Capacity	300.0Ah / 30.0 A	(10hr, 1.80V/cell, 25°C / 77°F)
	261.5Ah / 52.3 A	(5hr, 1.75V/cell, 25°C / 77°F)
	232.2Ah / 77.4 A	(3hr, 1.75V/cell, 25°C / 77°F)
	177.0Ah / 177.0 A	(1hr, 1.65V/cell, 25°C / 77°F)
Max. Discharge Current	1500A (5s)	
Internal Resistance	Approx 0.72mΩ	
Operating Temp. Range	Discharge : -20 ~ 60°C (-4 ~ 140°F)	
	Charge : -0 ~ 50°C (32 ~ 122°F)	
	Storage : -20 ~ 60°C (-4 ~ 140°F)	
Nominal Operating Temp. Range	25 ± 5°C (77 ± 41°F)	
Cycle Use	Initial Charging Current less than 60.0A	
	Voltage: 2.43VPC ~ 2.47VPC at 25°C (77°F)	
	Temp. Coefficient: -4mV/°C	
Standby Use	Initial Charging Current less than 60.0A	
	Voltage: 2.27VPC ~ 2.30VPC at 25°C (77°F)	
	Temp. Coefficient: -3mV/°C	
Capacity affected by Temperature	40°C (104°F)	103%
	25°C (77°F)	100%
	0°C (32°F)	86%
Self Discharge	Fully charged Kaise Solar Series batteries may be stored for up to 6 months at 25°C (77°F) and then a freshening charge is required. For higher temperatures the time interval will be shorter.	

## Constant Current Discharge (Amperes) at 25°C (77°F)

Volts/cell	15min	30min	1h	3h	5h	8h	10h
1.80V	349.7	245.7	158.7	75.0	51.0	35.9	30.0
1.75V	378.8	257.1	165.0	77.4	52.3	36.5	30.4
1.70V	407.0	269.0	171.3	79.8	53.7	37.0	30.8
1.65V	434.6	281.4	177.0	82.0	55.1	37.6	31.3
1.60V	463.8	293.1	183.3	84.6	56.6	38.0	31.6

## Dimensions and Terminal (Unit: mm (inches))

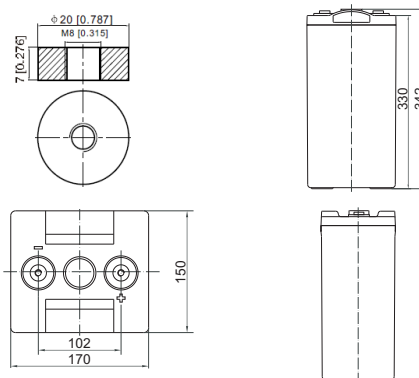

## Applications

- Renewable Energy
- Alarm systems
- Electric Test Equipment
- Emergency lighting systems
- Marine equipment
- Telecommunications systems

## Certifications

ISO 9001:2008 ISO 14001:2008



## Discharge Current vs. Discharge Voltage

Final discharge voltage V/CELL	1.8	1.75	1.7	1.6
Discharge current (A)	$I \leq 0.1CA$	$0.25CA \geq I > 0.1CA$	$0.55CA \geq I > 0.25CA$	$I > 0.55CA$

## Constant Power Discharge (Watts per cell) at 25°C (77°F)

Volts/cell	15min	30min	1h	3h	5h	8h	10h
1.80V	647.9	464.8	305.4	145.7	99.7	70.7	59.3
1.75V	691.9	481.5	315.7	149.7	102.0	71.8	60.0
1.70V	732.9	498.6	325.7	153.7	104.3	72.6	60.7
1.65V	771.0	516.5	334.6	157.3	106.7	73.6	61.5
1.60V	810.8	532.4	344.5	161.6	109.1	74.3	62.2

(Note) The above characteristics data are average values obtained within three charge/discharge cycles not the minimum values.

## Charging Characteristic (cycle use)

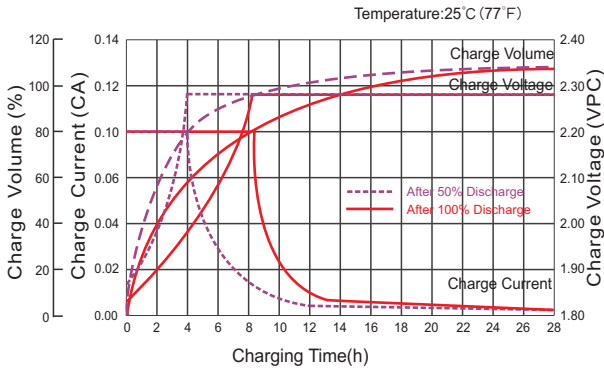

## Discharge Characteristics

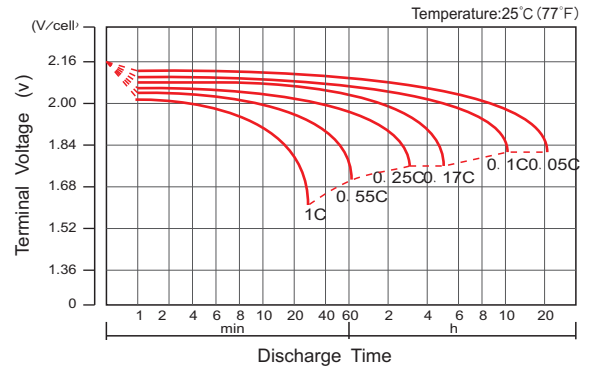

## Cycle Life In Relation To Depth Of Discharge

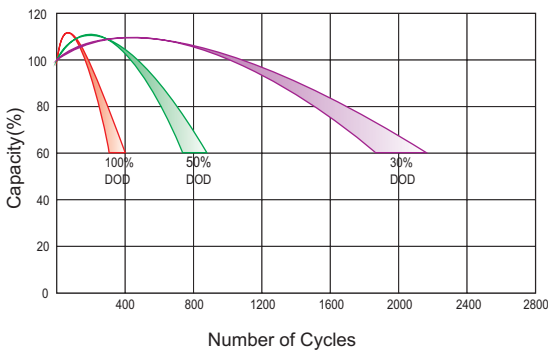

## Relationship Between Charging Voltage And Temperature

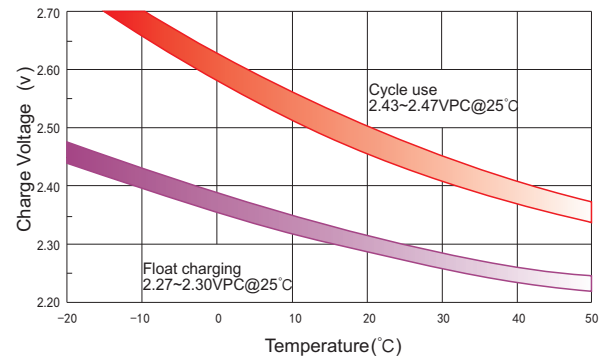

## Temperature Effects On Capacity

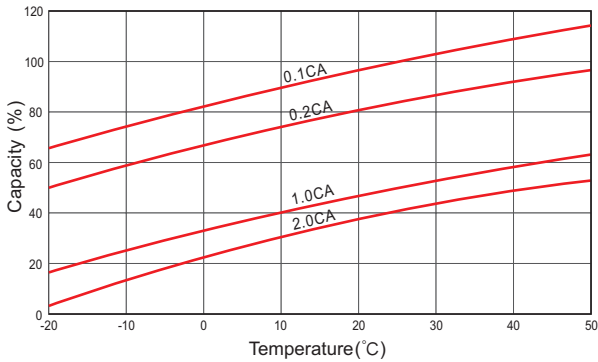

## Storage Characteristics

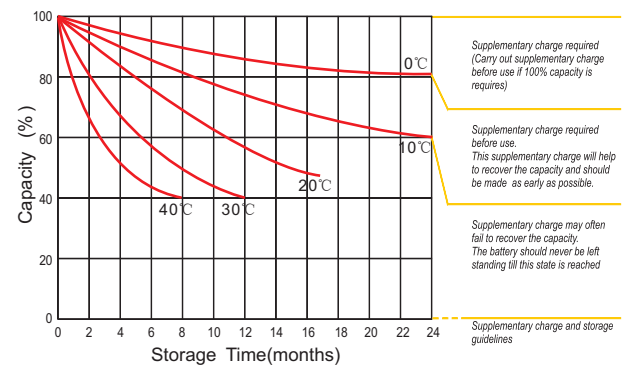

## Effect Of Temperature On Long Term Life

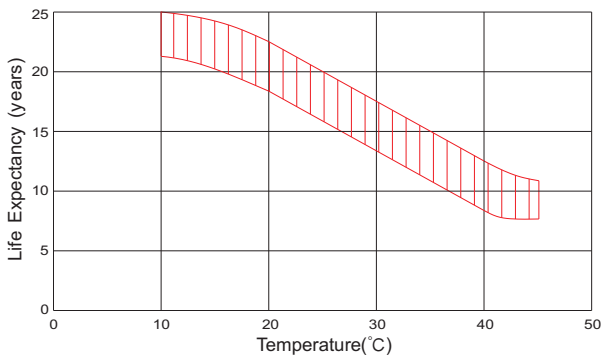

## Charge Characteristic Curve For Standby Use

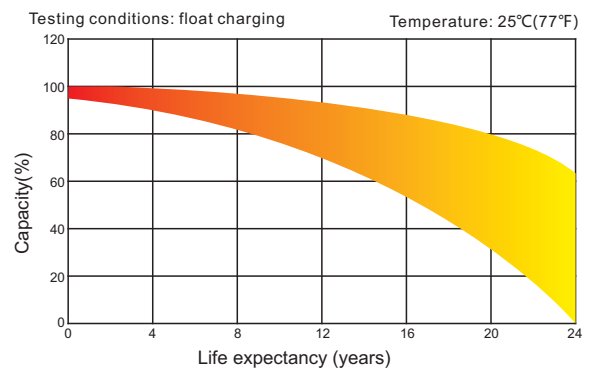

IMPORTANT NOTE: The specifications presented herein are subject to revision without notice.

2024/NT/R

