

KBC122300 12V 230Ah



The Kaise cyclic batteries were developed for deep discharges with very heavy non-porous battery plates to withstand major discharging and charging cycles (deep cycle). These batteries use different chemistry combinations for the plates with active paste material and a slightly stronger than normal electrolyte, which allows for a much longer life in deep cycle applications.

Performance Characteristics

Nominal Voltage	12V	
Dimensions	Length (mm / inch)	521±2 / 20.5
	Width (mm / inch)	269±2 / 10.6
	Height (mm / inch)	204±2 / 8.0
	Total Height (mm / inch)	209±2 / 8.2
Approx Weight	(Kg / lbs) 67.0 / 147.7	
Design Life	12 years (floating charge)	
Terminal	M8	
Container Material	A.B.S. UL94-HB, UL94-V0 Optional.	
Rated Capacity	230.0Ah / 11.50A	(20hr, 1.75V / cell, 25°C / 77°F)
	175.8Ah / 58.61A	(3hr, 1.75V / cell, 25°C / 77°F)
	126.5Ah / 126.5A	(1h, 1.75V / cell, 25°C / 77°F)
Max. Discharge Current	2300A (5s)	
Internal Resistance	Approx 3.0mΩ	
Operating Temp. Range	Discharge : -20 ~ 60°C (-4 ~ 131°F)	
	Charge : 0 ~ 50°C (32 ~ 122°F)	
	Storage : -20 ~ 60°C (5 ~ 140°F)	
Nominal Operating Temp. Range	25 ± 5°C	
Cycle Use	Initial Charging Current less than 69.0A	
	Voltage: 14.6V- 14.8V at 25°C (77°F)	
	Temp. Coefficient: -4mV/°C/Cell	
Standby Use	Initial Charging Current less than 69.0A	
	Voltage: 13.6V- 13.8V at 25°C (77°F)	
	Temp. Coefficient: -3mV/°C/Cell	
Capacity affected by Temperature	40°C (104°F)	103%
	25°C (77°F)	100%
	0°C (32°F)	86%
Self Discharge	Fully charged Kaise Deep Cycle Series batteries may be stored for up to 6 months at 25°C (77°F) and then a freshening charge is required. For higher temperatures the time interval will be shorter.	

Discharge Constant Current (Amperes) at 77°F (25°C)

Volts/cell	15min	30min	1h	3h	5h	10h	20h
1.80V	304.2	206.0	120.9	57.50	39.10	21.90	11.39
1.75V	332.2	213.9	126.5	58.61	39.61	22.12	11.50
1.70V	354.7	222.7	130.6	60.15	40.75	22.34	11.71
1.65V	377.1	234.9	134.9	62.81	41.88	22.78	11.86
1.60V	403.3	248.0	139.7	64.80	43.24	23.00	11.92

Dimensions and Terminal (Unit: mm (inches))

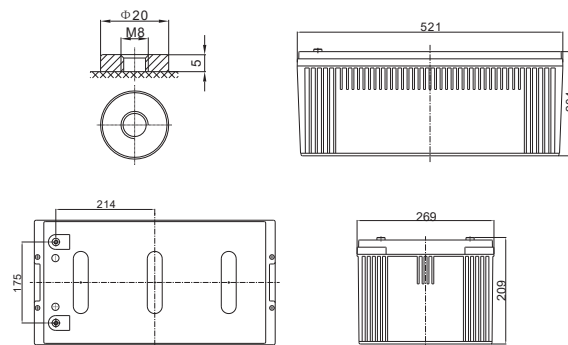

Applications

- Solar power systems
- Electric wheel chairs
- Golf carts
- Maritime equipment
- Power plants
- Railway systems
- Telecommunications systems
- Cable TV systems
- Emergency power systems

Certifications

ISO 9001 / ISO 14001



Discharge Current vs. Discharge Voltage

Final discharge voltage V/CELL	1.8	1.75	1.7	1.6
Discharge current (A)	$I \leq 0.1CA$	$0.25CA \geq I > 0.1CA$	$0.55CA \geq I > 0.25CA$	$I > 0.55CA$

Discharge Constant Power (Watts per cell) at 77°F (25°C)

Volts/cell	15min	30min	1h	2h	3h	5h	8h
1.80V	564.9	391.1	233.3	140.7	111.9	74.85	51.24
1.75V	611.1	404.2	243.3	143.9	112.5	75.87	52.10
1.70V	647.4	418.8	250.2	149.2	115.4	77.64	52.96
1.65V	684.0	440.0	257.8	153.0	120.0	79.63	53.61
1.60V	703.5	450.6	262.2	157.3	123.0	81.84	54.05

(Note) The above characteristics data are average values obtained within three charge/discharge cycles not the minimum values.

Charge Characteristic Curve for Cycle Use(IU)

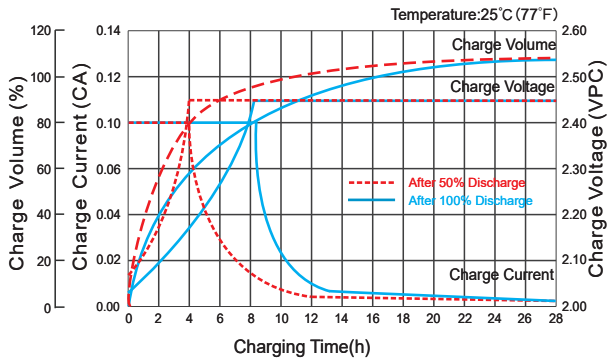

Discharge Characteristics Curve

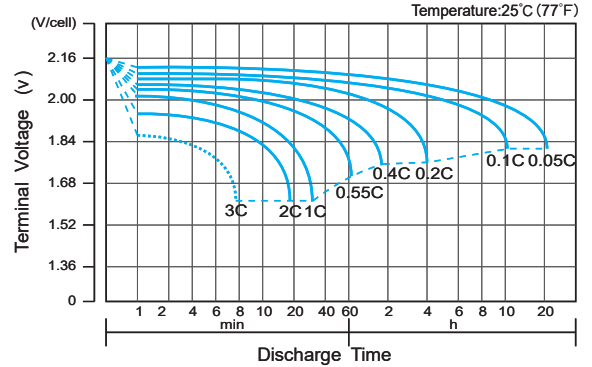

Cycle Life in Relation to Depth of Discharge

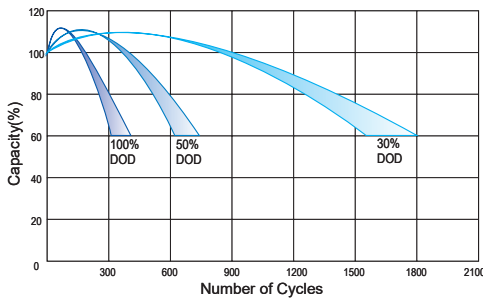

Relationship Between Charging Voltage and Temperature

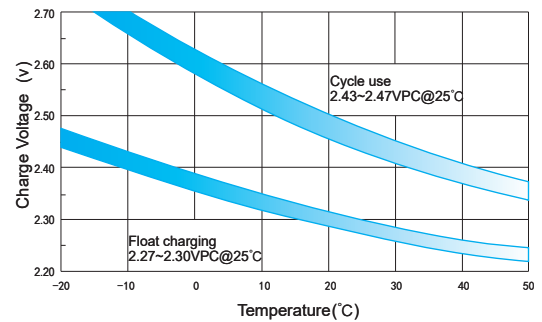

Temperature Effects in Relation to Battery Capacity

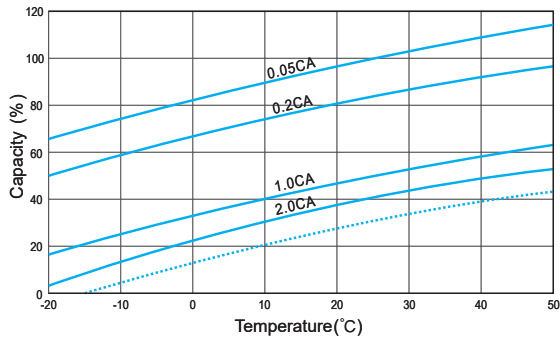

Storage Characteristics

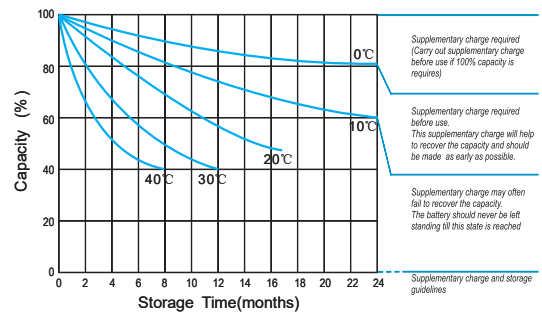

Effect Of Temperature On Long Term Life

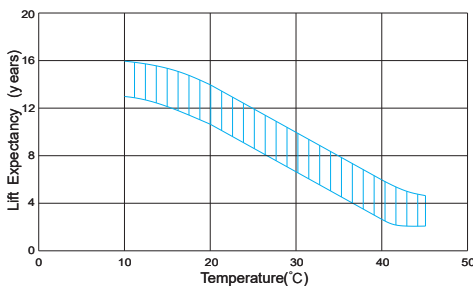

Relationship of OCV And State of Charge (20°C)

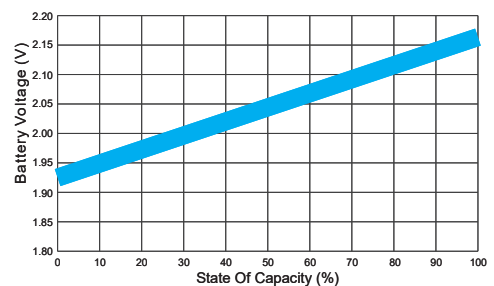

IMPORTANT NOTE: The specifications presented herein are subject to revision without notice.

